

RE10N

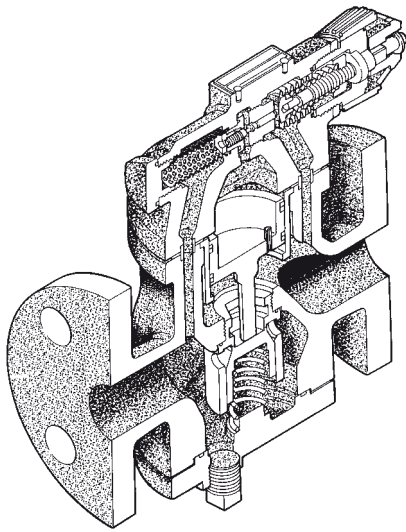

Dimensions RE10N

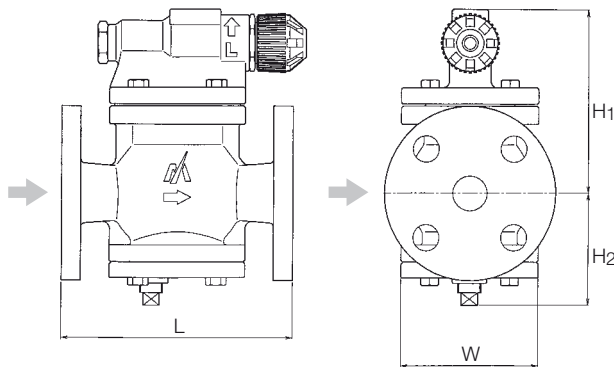

Capacity Charts RE10N

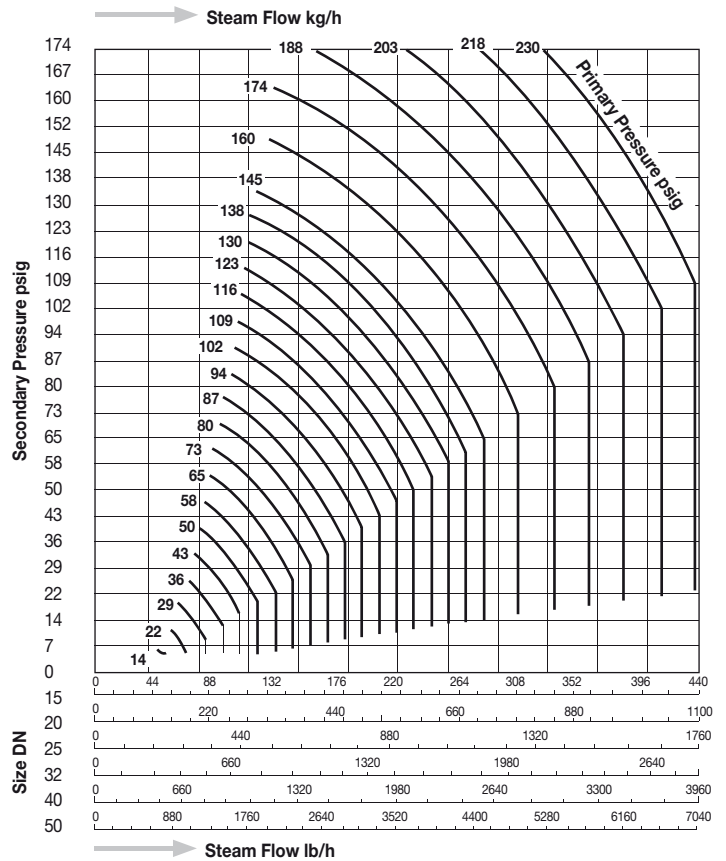
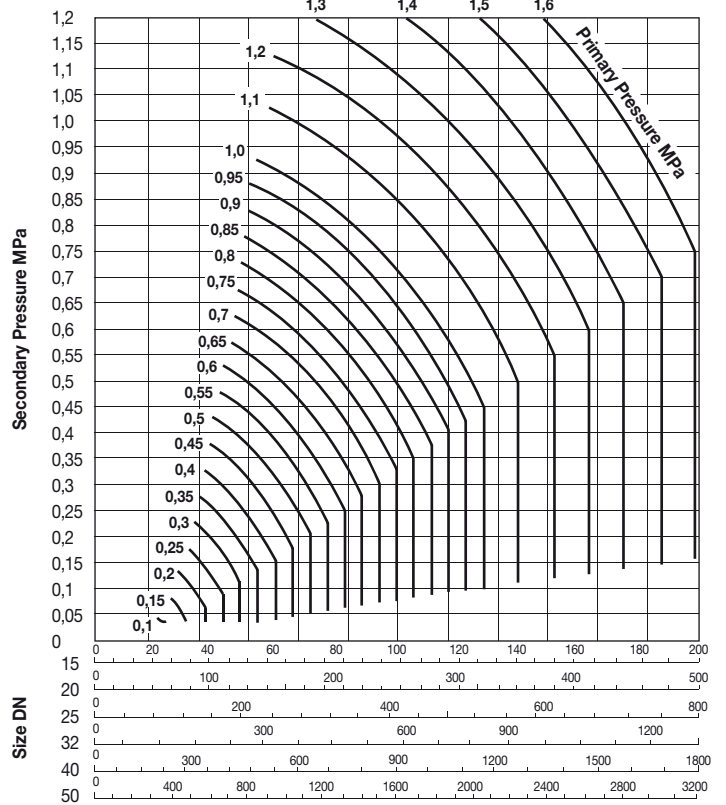

Model	Connections	Size	Operating Pressure (Primary)		Secondary Pressure		Max. Red. Pressure Ratio	Max. Oper. Temperature		Dimensions (mm)				Dimensions (in)				Body Material	Weight	
			MPa	psig	MPa	psig		°C	°F	L	H ₁	H ₂	W	L	H ₁	H ₂	W		kg	lb
RE10N	Flanged	DN 15	0,1 – 1,6	14,5 – 230	0,03 – 1,2	4,4 – 174	20 : 1	220	428	160	133	80	100	6.3	5.2	3.1	3.9	Ductile Cast Iron FCD450	7,0	15,4
		DN 20								170	6.7	7,4	16,3							
		DN 25								200	7.9	8,1	17,8							
		DN 32								154	103	130	6.1	4.1	5.1	14,1	31,0			
		DN 40								220	8.7	14,3	31,5							
DN 50		15,5	34,1																	